

i-IQ/CCD™ SERIES

Advanced Color Sorting Technology + Durability =
Optimal Yield and Lowered Production Cost



Optical Sorters for Virtually Any Application

Coffee • Rice • Seeds • Cereals • Pulses • Nuts • Plastics • Many More



Sorting accuracy at the speed of light.

Using Delta-designed cameras, products are scanned 8,000 times per second, creating sorting accuracy that is unachievable by any other method.

Images are converted using high speed, 2048 pixel monochromatic and 6,000 pixel RGB full color, high-resolution CCD technology, for extreme accuracy in detecting even the smallest defects.



- Two cameras per tray, mounted on the front and rear for dual-side viewing of your product.
- Designed by Delta engineers, the new generation Digital Signal Processor operates at optimal data processing speed. Sophisticated sorting algorithms create maximum sorting efficiencies, and there is virtually no time delay between defect signal and ejector activation.



i-IQ/CCD Models

- i-IQ/CCD 2-126 Channels
- i-IQ/CCD 3-189 Channels
- i-IQ/CCD 4-252 Channels
- i-IQ/CCD 5-315 Channels

All models feature adjustable primary and resort capabilities.

Ejectors that define durability and reliability.

Delta's patented, high-speed pneumatic ejectors are machined to the highest tolerances in the industry.

- Precision manufacturing, special metal alloys and custom hardening techniques produce an ejector with an exceptionally long life.
- Minimizes maintenance downtime and costs.
- Ejector array is highly concentrated for the greatest sorting accuracy and minimal loss of good product.



The world's friendliest optical sorter.

The i-IQ/CCD series continues the Delta philosophy of making operation easy and intuitive.

- Pre-set sorting mode provides fast setup for different products.
- Automatic calibration for fast and easy setups.
- Fault detection system within each sorter for easy and rapid diagnostics.
- Unique pulse width modulation (PWM) feeders ensure a constant feed of product and reduce power consumption by 15-20%.
- Large, easy-to-read LCD full color touch screen.





Intelligent Design = Lowest Maintenance Cost + Minimal Downtime

Delta's Reliability and Service Assurance

- Highly trained Delta technicians assist customers with sorter specifications, options, start up and on-site training.
- Each sorter has its own fault detection system for immediate diagnostics.
- Long life precision ejectors minimize maintenance costs.
- Feeder trays have aircraft coating for durability and minimal friction.
- Advanced LED illumination system with no frequent changeover of lamps required and low power consumption.
- Localized technical support in most countries.



i-IQ/CCD™ SERIES

Innovative Technology Achieves Optimal Yields



ABOUT US

As the sorter industry's innovation leader, Delta Technology provides solutions and experience that allow our clients to enjoy optimal yields and efficiencies. When those attributes are combined with our sorters' ruggedness, competitive pricing and maintenance programs, it's easy to see why the most cost effective sorters in the world come from Delta Technology.

In business for 30+ years under the same ownership, we value product excellence, integrity, teamwork and continual self-improvement, both as a company and as individuals. We are passionate about technology and quality, and we hold ourselves absolutely accountable to our most important stakeholders, our customers. Contact us for your specific application needs.

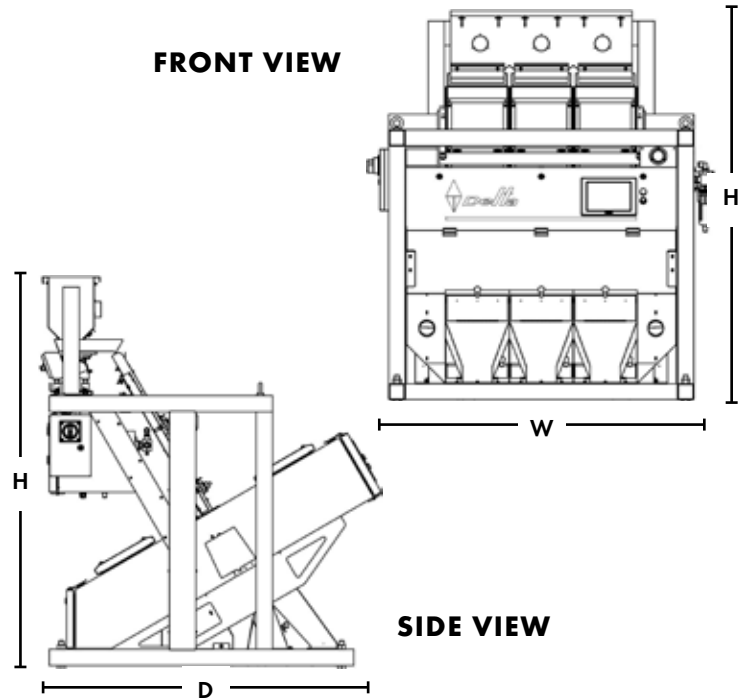

Available in these configurations to meet your throughput and resort requirements: 126, 189, 252 and 315 channels.

TECHNICAL DATA

Model	i- IQ/TCS-2	i- IQ/TCS-3	i- IQ/TCS-4	i- IQ/TCS-5
Electrical	110 or 220 VAC 50 or 60 Hz, single phase power 1.8 KW	110 or 220 VAC 50 or 60 Hz, single phase power 2.7 KW	110 or 220 VAC 50 or 60 Hz, single phase power 3.0 KW	110 or 220 VAC 50 or 60 Hz, single phase power 3.3 KW
Air	52 CFM @ 90 - 120 PSI 1.4 m ³ /minute @ 6 - 8 Bar	78 CFM @ 90 - 120 PSI 2.2 m ³ /minute @ 6 - 8 Bar	104 CFM @ 90 - 120 PSI 2.9 m ³ /minute @ 6 - 8 Bar	130 CFM @ 90 - 120 PSI 3.7 m ³ /minute @ 6 - 8 Bar
Operating Temperature	40°F - 95° F 5°C - 35°C	40°F - 95° F 5°C - 35°C	40°F - 95° F 5°C - 35°C	40°F - 95° F 5°C - 35°C
Net Weight	750 Kg/1653 lbs	800 Kg/1763 lbs	900 Kg/ 1984 lbs	1000 Kg/ 2204 lbs
Width	1312 mm/52 in	1660 mm/65 in	2008 mm/79 in	2356 mm/93 in
Depth	1620 mm/64 in	1620 mm/64 in	1620 mm/64 in	1620 mm/64 in
Height	1890 mm/74 in	1890 mm/74 in	1890 mm/74 in	1890 mm/74 in

www.deltatechnology.com • 1602 Townhurst • Houston, Texas 77043 USA
Phone: 713.464.7407 • Fax: 713.461.6753 • E-mail: info@deltatechnology.com